

# Pennsylvania Switchgear

## HIGH VOLTAGE DEAD TANK CIRCUIT BREAKERS

# PB 72

Family of Breakers

72.5kV • 40kA

### Superior Performance

The PB72 breaker family delivers superior performance with advanced spring and interrupter technology:

- Tested to L30 line fault duties for proper interruption at typical short-circuit levels
- First-pole-to-clear factor of 1.5 at 170kV for ungrounded and improved grounded system performance
- High asymmetry ratio of 33, nearly double the standard required ratio of 17
- 50kA short-time current test, 25% above standard, with no deformation or welding of contacts
- Certified for Definite Purpose For Fast Transient Recovery Rise Times per ANSI C37.06.1

### Ease of Maintenance

Maintenance is simplified with built-in lube fittings on all main bearings, hand-charging via a standard wrench, and auxiliary switches mounted directly on the mechanism—eliminating the need for special tools or linkage adjustments.

### PB72 Breakers - Performance, Reliability, Simplicity

The PB72 Family of High-Voltage Dead-Tank Circuit Breakers (38.5-72.5kV) combines proven performance with easy maintenance and long-term reliability. With advanced insulation, efficient heating, and customizable options, they deliver dependable protection in even the toughest conditions.

#### Tank Cross Section

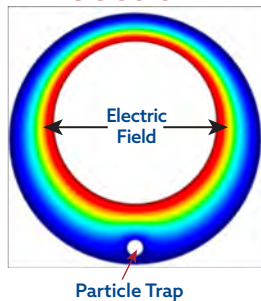

#### Integral Particle Trap/Tank Heater

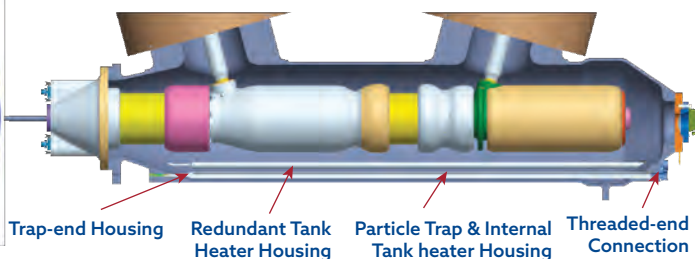

#### Design Features

**Integral Particle Trap:** Improved dielectric performance is achieved through the patented particle trap design, integral to each interrupter's enclosure. The trap ensures that any particles or arc by-products generated during breaker operations are electrically shielded at the enclosure's lowest point.

#### Internal Tank Heater

**Specialized Heater Element:** Unlike conventional external heaters, Pennsylvania Switchgear heaters are installed inside the tank to directly heat the SF6 gas. The heater element can be replaced within minutes without opening the tank or removing the SF6 gas.



Pennsylvania Switchgear  
A Division of Pennsylvania Transformer Technology, LLC  
(724) 873-2100 • sales@paswitchgear.com  
30 Curry Avenue, Canonsburg, PA 15317



paswitchgear.com

# HIGH VOLTAGE DEAD TANK CIRCUIT BREAKERS

PERFORMANCE.  
RELIABILITY. SIMPLICITY.

## Standard Features

- Integral particle trap
- Porcelain insulators
- Galvanized support frame
- Powder-coated control cabinet
- Stainless steel door handles
- Stainless steel SF6 tubing
- Ganged SF6 monitoring
- SAE hardware
- Fully assembled shipments

## Optional Features

- Low temperature performance to -30°
- ASME Pressure Vessel Certification
- Internal tank heater
- High seismic performance
- Individually-phased SF6 monitoring
- NEMA four-hole universal positioning terminals
- Custom control package
- Extra auxiliary contacts
- Custom support structure
- Side-mounted position indicator for long-distance viewing

Coupling the reliable SSM-1.6 Spring-Operating Mechanism with proven self-blast interrupter technology, the PB72 breaker family provides superior performance.

Inches	A	B	C	D	E	F	G	H	J	K	L	M	N	O	P
PB72	114	57	51	54	42	122	100	35	28	27	22	147	84	58	30

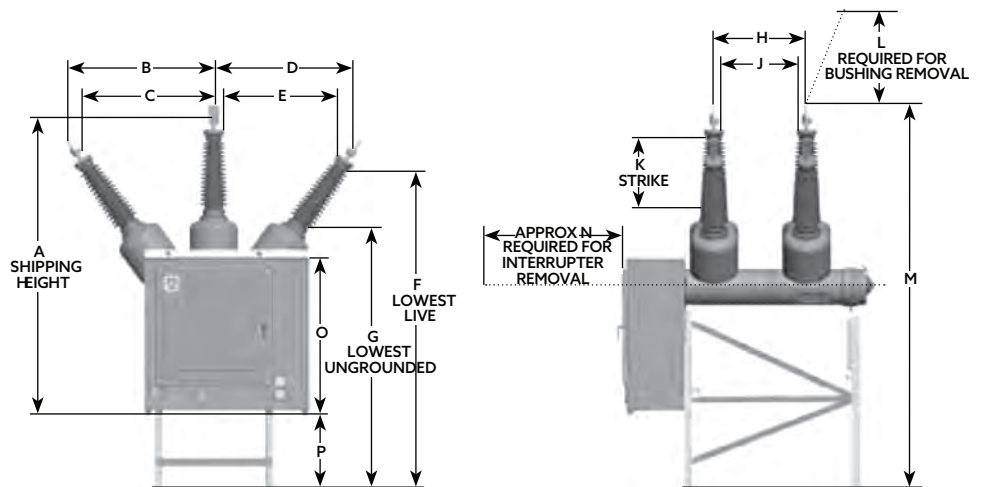

RATINGS	PB72
Standards	ANSI/IEEE
Maximum Voltage	72.5kV
BL	350kV
Frequency	60Hz
60Hz Withstand	160kV
Short-Circuit Current	40kA
Continuous Current	2kA/3kA
Interrupting Time	3 cycles
Duty Cycle	O-0.3s-CO-15s-CO
Temperature	-30°C to +50°C
Altitude above sea level	Up to 3,300ft
Seismic (IEEE 693-2005)	High
Normal Operating Pressure	90psig@20°C
Minimum pressure to interrupt fault current	76psig@20°C
Minimum pressure to interrupt load current	76psig@20°C

## Operating Mechanism

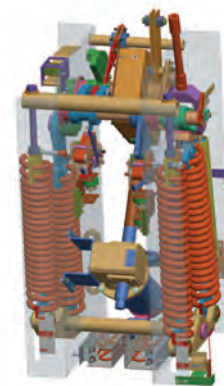

The mechanism's open design provides ready access to all components. It is designed to provide reliable 3-cycle performance with minimal maintenance.



Pennsylvania Switchgear  
A Division of Pennsylvania Transformer Technology, LLC  
(724) 873-2100 • sales@paswitchgear.com  
30 Curry Avenue, Canonsburg, PA 15317



paswitchgear.com